

Double Suction Pumps

DanPumps S-DSP (DN 65 - DN 600

mm) Product Applications The DanPumps S-DSP pump is designed for clean or slightly contaminated low viscosity liquids without solid and fibrous particles.

Technical data

Discharge Flange	DN 65 - DN 600 mm
Capacity	up to 6000 m ³ /h
Head	up to 180 m
Speed	up to 2900 rpm
Design Temperature	-10° C to +110° C*
Casing Pressure (Pmax**)	16 bar - 25 bar*

* The Material of pumps dier according to the type of pumped liquid, operating temperature and pressure. Contact for detailed information.

** Pmax: Suction Pressure + Shut off Head

Pump Designation

S-DSP **200** - **500**
Pump type Discharge Nozzle (DN-mm) Nominal Impeller Diameter (mm)



Design Features:

- Horizontal or vertical manufacturing option. Axial split case, single stage, double suction centrifugal pumps.
- Suction and discharge flanges are on the same axis on the bottom casing. Split case design permits easy disassembly of the rotor group for maintenance or repair without distorting pump alignment and suction/discharge piping.
- Suction and Discharge Flanges are conform to EN 1092-2/PN 16 or PN 25. (EN 1092-1/PN 16 or PN 25 for steel or stainless steel casing).
- All impellers are balanced dynamically or statically according to ISO 1940 class 6.3.
- Impeller is of double suction design. This feature increases pump suction performance in addition to providing the balance of hydraulic axial forces resulting in higher bearing life and higher reliability.
- In standard construction, the direction of rotation is clockwise when it is looked from drive end. In this case, suction flange is on right and discharge flange is on left. Upon request, the direction of rotation can be reversed. This time the position of the suction and discharge flanges are also reversed.
- Grease lubricated ball bearings are used in horizontal installation. In case of vertical installation, pumping liquid lubricated journal bearings on top and grease lubricated ball bearings on bottom are used.

Shaft Sealing

- The standard shaft seal is a mechanical Carbon/Silicon carbide with EPDM.
- Different seal variants are available depending on customer request and liquid type.



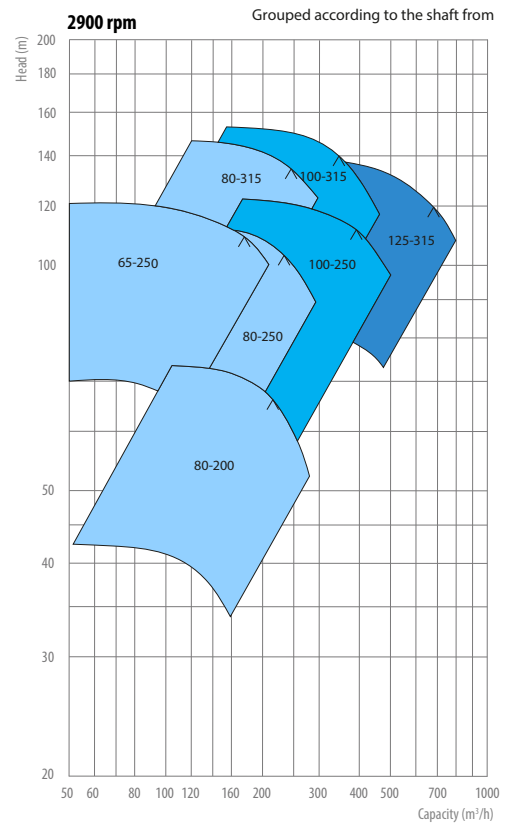
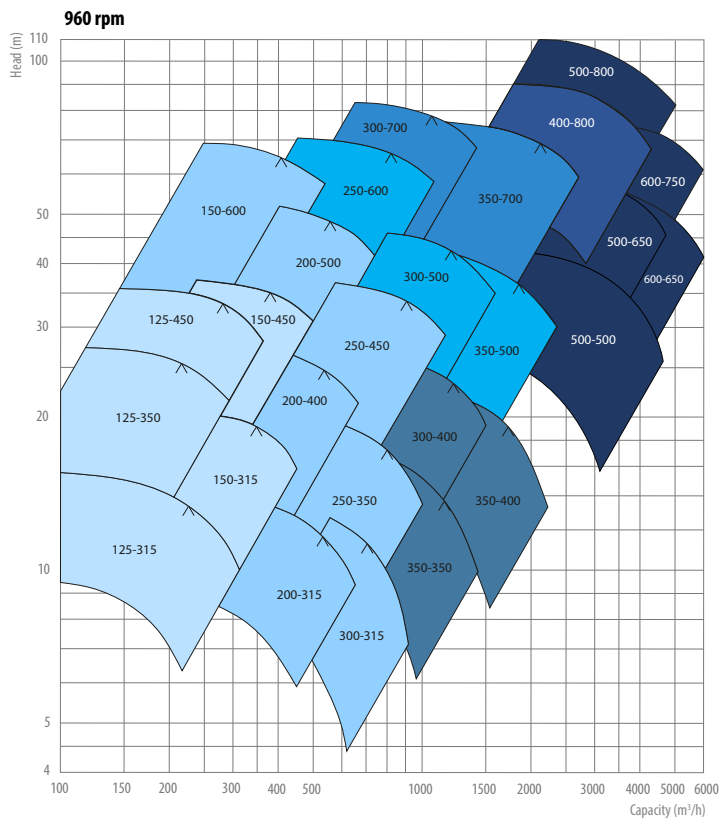
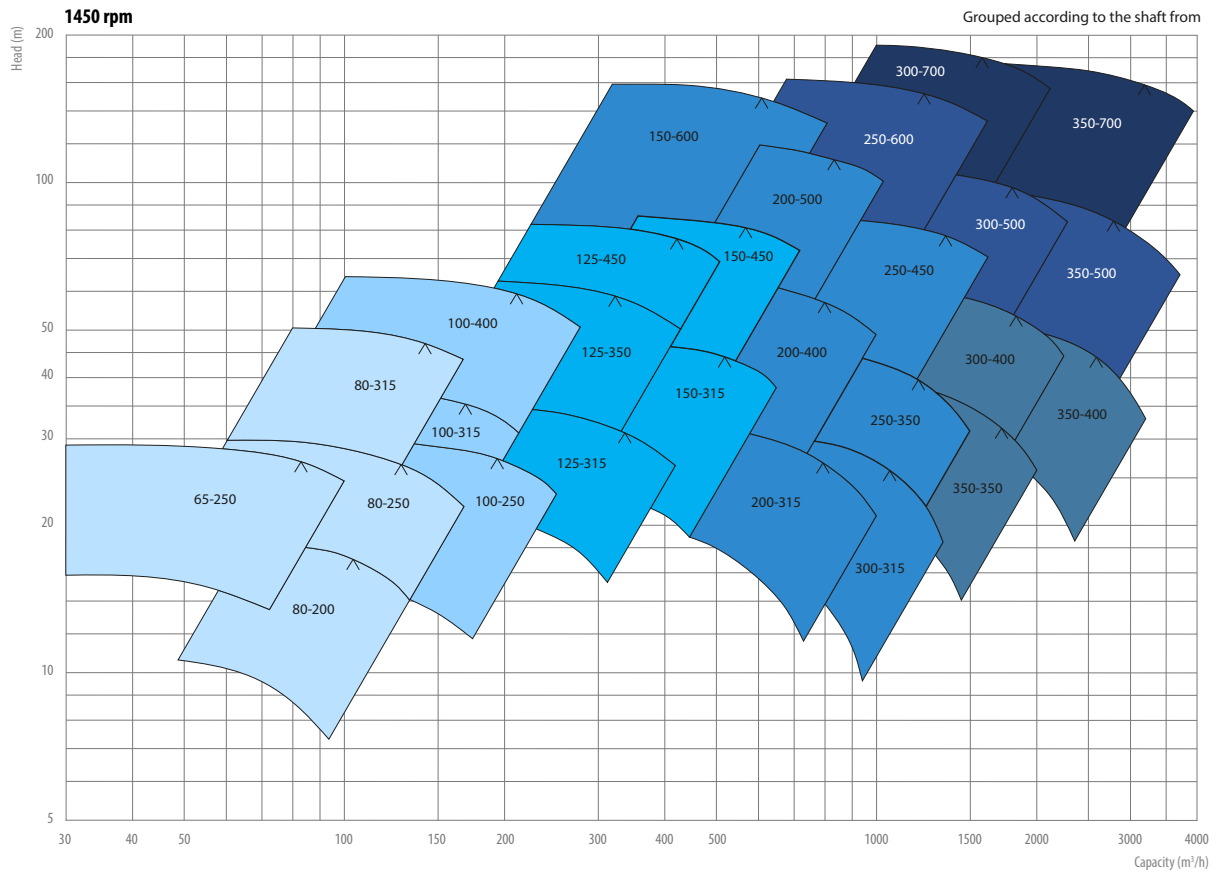

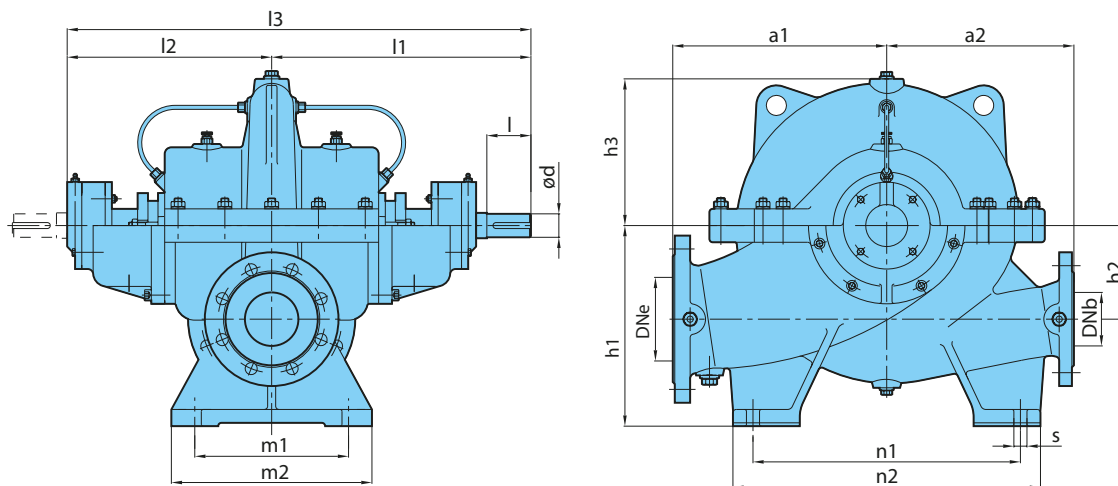

Pump type	Dimensions (mm)																			Weight (kg)
	PNe	PNb	DNe	DNb	ød	l	l1	l2	l3	a1	a2	h1	h2	h3	n1	n2	m1	m2	s	
65-250	16	16	100	65	35	80	400	310	710	320	280	300	140	200	400	460	230	300	20	165
80-200	16	16	125	80	35	80	400	310	710	320	280	300	140	200	400	460	230	300	20	165
80-250	16	16	125	80	35	80	400	310	710	320	280	300	140	200	400	460	230	300	20	175
80-315	16	16	125	80	35	80	400	310	710	360	300	300	140	260	400	460	230	300	20	197
100-250	16	16	150	100	42	90	450	350	800	360	310	355	170	235	400	480	280	340	20	220
100-315	16	16	150	100	42	90	450	350	800	360	310	355	170	250	400	480	280	340	20	230
100-400	16	16	150	100	42	90	450	350	800	420	370	355	170	300	460	540	280	340	20	290
125-315	16	16	200	125	55	120	555	420	975	420	370	400	200	280	460	540	320	380	22	330
125-350	16	16	200	125	55	120	555	420	975	470	450	400	200	300	540	660	320	380	22	380
125-450	16	16	200	125	55	120	555	420	975	500	450	400	200	350	540	640	320	380	22	410
150-315	16	16	200	150	55	120	555	420	975	470	400	400	200	310	540	640	320	380	22	395
150-450	16	16	200	150	55	120	555	420	975	500	450	400	200	365	540	640	320	380	22	430
150-600	25	25	250	150	65	130	645	500	1145	550	500	560	300	445	540	640	360	420	22	800
200-315	16	16	250	200	65	130	645	500	1145	500	450	500	240	315	540	640	360	420	22	570
200-400	16	16	250	200	65	130	645	500	1145	500	450	500	240	360	540	640	360	420	22	575
200-500	16	16	250	200	65	130	645	500	1145	550	500	560	300	380	620	720	360	420	22	700
250-350	16	16	300	250	65	130	645	500	1145	600	500	600	300	390	620	720	360	420	22	682
250-450	16	16	300	250	65	130	645	500	1145	600	500	600	300	415	620	720	360	420	22	780
250-600	25	25	300	250	80	170	720	540	1260	650	550	600	300	430	620	710	415	485	26	1190
300-315	16	16	350	300	65	130	645	500	1145	600	500	630	300	400	620	700	360	420	22	700
300-400	16	16	400	300	75	140	770	615	1385	700	550	710	350	450	720	800	420	520	26	1125
300-500	16	16	400	300	85	170	755	585	1340	700	750	710	350	425	700	800	420	520	26	1500
300-700	25	25	400	300	100	180	865	675	1540	750	800	710	350	470	720	880	420	520	26	1650
350-350	16	16	400	350	75	140	770	615	1385	700	550	670	350	450	720	800	420	520	26	1100
350-400	16	16	500	350	75	140	770	615	1385	800	600	800	380	500	800	960	500	600	26	1400
350-500	16	16	500	350	80	170	755	585	1340	800	600	800	400	435	740	900	500	600	26	1435
350-700	25	25	500	350	100	180	865	675	1540	850	750	850	450	525	720	880	500	600	26	2000
400-800	16	16	600	400	105	220	1035	810	1845	900	900	880	450	565	950	1120	630	740	26	3400
500-500	16	16	600	500																
500-650	16	16	600	500																
500-800	16	16	600	500																
600-650	16	16	700	600																
600-750	16	16	700	600																

Contact for detailed information

Technical Data

Part List	10	30	35	20	60	6L	70	7L	8M	7D	7S	8N	80	4C	4A	40	80	8T	60	7L	7E	7D	
	0.6025	0.7040	0.7043	1.0619	1.4308	1.4309	1.4408	1.4409	1.4500	1.4517	1.4469	1.4317	1.4008	2.1050.01	2.0975.01	2.1096.01	1.4021	1.4021+QT	1.4301	1.4404	1.4460	1.4462	
Volute Casing**	●	○	○	○	○	○	○	○	○	○	○	○	○	○									
Impeller	●	○	○	○	○	○	○	○	○	○	○	○	○	○	○	○						○	
Shaft																	○	○	○	●			○
Bearing House	●	○	○	○	○	○	○	○															
Wear Ring (Casing)	●	○	○	○	○	○	○	○	○	○	○	○	○	○	○	○							
Shaft Protecting Sleeve																	●	○	○	○			○
Mechanical Seal*	EN 12756																						

* Optional: Depending on customer requirement or request different types and brands of mechanical seals are applicable.
 ** 0.7040 material is used in standard production for types which has PN 25 casing pressure class

● Standard manufacturing
 ○ Optional

Material Equivalents

Description	DIN / EN		AISI / SAE / ASTM
Cast Iron	0.6025	EN-GJL-250 (GG25)	A48 Class 40B
Nodular Cast Iron	0.7040	EN-GJS-400-15 (GGG40)	A536 60-40-18
Nodular Cast Iron	0.7043	EN-GJS-400-18-LT (GGG40.3)	A536 60-40-18
Cast Steel	1.0619	GP240GHGS-C25	A216 WCB
Chrome Nickel Cast Steel	1.4308	GX5CrNi19-10	A351 CF8
Chrome Nickel Cast Steel (low carbon)	1.4309	GX2CrNi19-11	A351 CF3
Chrome Nickel Molybdenum Cast Steel	1.4408	GX5CrNiMo19-11-2	A351 CF8M
Chrome Nickel Molybdenum Cast Steel (low carbon)	1.4409	GX2CrNiMo19-11-2	A351 CF3M
Austenitic Cast Steel	1.4500	GX7NiCrMoCuNb25-20	A351 CN7M
Austenitic - Ferritic Cast Steel (duplex)	1.4517	GX2CrNiMoCuN25-6-3-3	A890 CD4MCuN
Austenitic - Ferritic Cast Steel (super duplex)	1.4469	GX2CrNiMoN26-7-4	A890 CE3MN
Martenzitic Stainless Cast Steel	1.4317	GX4CrNi13-4	A352 CA6NM
Martenzitic Stainless Cast Steel	1.4008	GX7CrNiMo12-1	A217 CA15
Cast Bronze (tin alloy)	2.1050.01	G-CuSn10	B427 C90700
Cast Bronze (nickel alloy)	2.0975.01	G-CuAl10Ni	B148 C95500
Cast Bronze (Leaded)	2.1096.01	G-CuSn5ZnPb	B584 C83600
Chrome Steel	1.4021	X20Cr13	A276 Type 420
Chrome Steel (Heat treated)	1.4021	X20Cr13	A276 Type 420+QT
Chrome Nickel Steel	1.4301	X5CrNi18-10	A276 Type 304
Chrome Nickel Steel (low carbon)	1.4404	X2CrNiMo17-12-2	A276 Type 316L
Duplex (austenitic-ferritic) Steel	1.4460	X3CrNiMoN27-5-2	AISI 329
Duplex (austenitic-ferritic) Steel	1.4462	X2CrNiMoN22-5-3	UNS S32205

Pump weight= G + (s x g) (s: number of stage)

Flange Dimensions

EN 1092 - 2	DNe/ DNb	Suction & Discharge (PN 16)				Suction & Discharge (PN 25)			
	Df	k	s	n	Df	k	s	n	
65	185	145	19	4	185	145	19	8	
80	200	160	19	8	200	160	19	8	
100	220	180	19	8	235	190	23	8	
125	250	210	19	8	270	220	28	8	
150	285	240	23	8	300	250	28	8	
200	340	295	23	12	360	310	28	12	
250	405	355	28	12	425	370	31	12	
300	460	410	28	12	485	430	31	16	
350	520	470	28	16	555	490	34	16	
400	580	525	31	16	620	550	37	16	
500	715	650	34	20	730	660	37	20	
600	840	770	37	20	845	770	41	20	
700	910	840	37	24	960	875	41	24	

"n" number of holes

