

ABS SOLUTIONS FOR MIXING AND AGITATION.

POMP  DIRECT

We know how water works

YOU WANT MOVEMENT. WE ADD DIRECTION.

Wastewater treatment plant operators around the world face dramatic increases in the cost of energy and are under constant pressure to reduce the amount of energy consumed and with it the level of CO₂ emissions into the atmosphere. At ABS our goal is to help these operators reduce their energy costs and improve the reliability of the treatment process.

ABS has one of the widest product portfolios in the world for mixing and agitation. To be able to offer the optimal solution to every customer's needs we have both submersible and dry-installed equipment. Our hands-on experience together is put to work in the R&D process to make sure ABS mixers and agitators are the best choice when you look at the total cost throughout the entire life cycle of the equipment. The modular ABS mixer system in combination with flexible mixer positioning and easy installation guarantees a solution with the optimum life cycle cost.

Working together in the selection process

ABS has its own software tool for equipment selection. The program utilizes our vast experience from more than 150,000 operational installations. Customers can be sure of an optimal solution based on a consideration of the following factors:

- Purpose of application
- Tank shape
- Tank dimensions
- Medium to be mixed
- Viscosity, specific weight and dry-matter content etc.
- Temperature

ABS software for mixer selection.

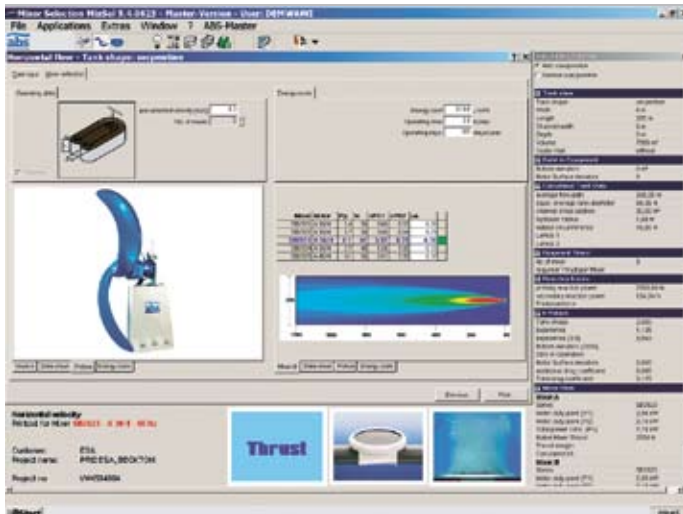



Thrust measurement facility regarding ISO 21630.

The mixer thrust

The mixer thrust is an important parameter in the determination of the mixing result and therefore of major importance in the selection process. The performance of a submersible mixer can be expressed by thrust (N) or the flow capacity (l/s) that it produces. All mixing applications require a certain degree of turbulence and bulk flow which is generated by the propeller jet reaction force – the mixer thrust.

The target when designing a mixing application is to achieve optimal bulk flow, since with an optimal bulk flow the entire contents of the tank are in motion. The bulk flow is a function of the impeller jet flow which is closely related to the mixer thrust. Consequently the mixer thrust together with the mixer positioning form the basis of good mixer selection.

Relation of thrust to bulk flow.

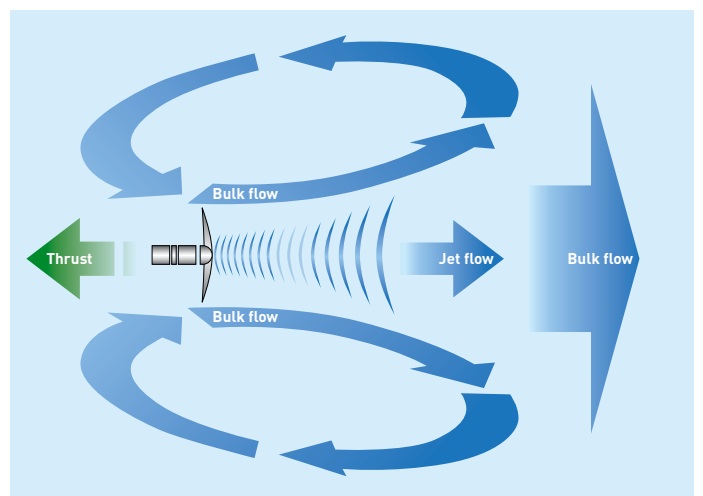

DIFFERENT APPLICATIONS NEED DIFFERENT SOLUTIONS.

A) Pre-treatment

NEUTRALIZATION

Neutralization is the pH adjustment process in the pre-treatment stage achieved by flash and contact mixing of added chemicals in the neutralization tank. ABS Scaba agitators facilitate the proper mixing of chemicals and wastewater.

FLOCCULATION

Flocculation is a chemical/physical process which is performed during the biological pre-treatment process to remove unwanted chemicals. Gentle mixing characterized by low shear forces is achieved by the ABS Scaba agitators. They ensure good mixing of the flocculants and the liquid while at the same time preventing sedimentation.

B) Equalization

The objective of mixing during the equalization process is to blend the wastewater and to prevent sedimentation, stratification and odour formation. The ABS submersible

mixers RW are the best solution, since the water levels in this part of the process are often very low and have a tendency to frequently change. Which RW model to use is determined by the intensity of mixing and flow required.

C) Selector (Contact zone)

In the selector tank the aim is to control and limit the growth of filamentous bacteria, which enhances the sludge sedimentation ability. Submersible mixers and Scaba agitators are used for intensive (flash) mixing of the re-circulated sludge and wastewater.

D) Biological process (secondary and tertiary)

ANAEROBIC AND ANOXIC

In the anaerobic and anoxic tanks the biomass has to be kept in suspension in order to avoid the risk of the sludge settling and to maximize the active volume. The target is to provide good contact between the inlet wastewater, re-circulated sludge

and biomass. Both the dry installed ABS Scaba agitators and the submersible mixers can be used to provide sufficient mixing energy to keep the biomass in suspension. Some plants use a moving bed biofilm reactor (MBBR) with plastic carriers in the biological process. The ABS submersible mixer SB 1200 KA has been specifically developed for this process.

NITRIFICATION

In all tanks where a simultaneous DN-N process takes place the ABS flow booster SB generates an optimal and efficient mixing level when the aeration system is inactive i.e. when denitrification takes place.

DENITRIFICATION

In the denitrification process the flow generated by the ABS flow booster SB prevents settlement and achieves good biomass mixing and circulation. It is critical that the units are sized and installed in the correct way to avoid turbulence.

-  1 ABS submersible mixer RW 200-280
-  2 ABS submersible mixer RW 480
-  3 ABS submersible mixer RW 300-900
-  4 ABS flow booster SB 900-2500
-  5 ABS submersible mixer SB 1200 KA
-  6 ABS Scaba agitator

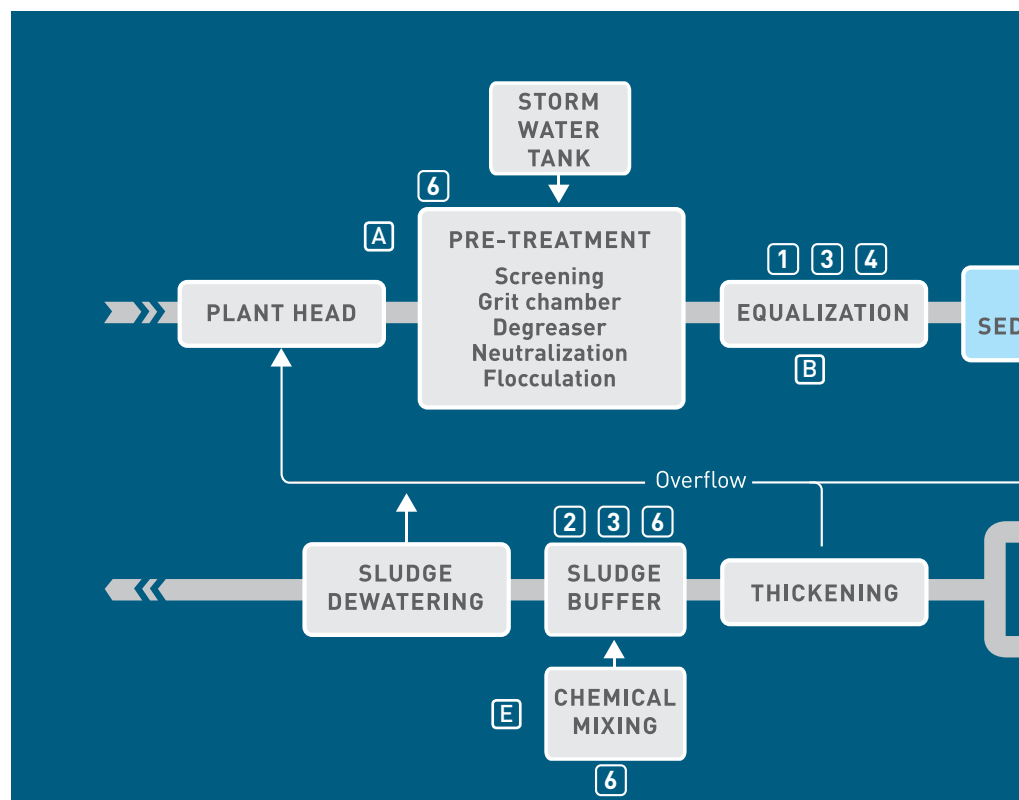

PHOSPHATE REMOVAL

The horizontal flow generated by ABS flow boosters SB efficiently creates an even distribution of the chemical flocculants introduced into the wastewater to produce flocs suitable for catching the phosphates.

E) Chemical mixing

The activated sludge must sometimes be mixed with chemicals before it enters the secondary sedimentation tank. Chemicals are for example used to remove phosphates or to make flocculants settle more rapidly.

ABS Scaba agitators can be used successfully to mix these chemicals evenly with the treated wastewater.

F) Anaerobic digestion

Common for many digester designs are the requirements for biomass homogenization, temperature equalization, breaking of floating crusts and prevention of foam formation. The most efficient solution uses the slow running ABS Scaba agitators with large propellers and high flow capacity.

G) Sludge buffer tank

Blending and homogenization of concentrated primary, secondary or digested sludge are the most common application in the sludge buffer tanks. Both dry installed ABS Scaba agitators and ABS submersible mixers can be successfully used.

Submersible or dry installed?

In a number of the wastewater treatment applications for mixing and agitation both submersible and dry installed solutions can be used. Normally the physical conditions like tank size and volume determines which solution to use. However, other factors like operation and maintenance requirements or strategy determines the preferred solution. At ABS we offer both solutions and can advise the customer by highlighting the pros and cons of the different options.

	RW 200-280	RW 480	RW 300-900	SB 900-2500	SB 1200 KA	Scaba agitator
Propeller diameter	7.87-11.02 in	18.90 in	11.81- 35.43 in	35.43-98.43 in	35.43- 42.52 in	5.91-0.39 in
Rated motor power	1.61-3.75 hp	10.05-14.75 hp	2.01-29.5 hp	1.88-6.17 hp	4.02-6.17 hp	0.16-402.3 hp
Mixer thrust up to	320 N	2000 N	5225 N	3800 N	1420 N	-

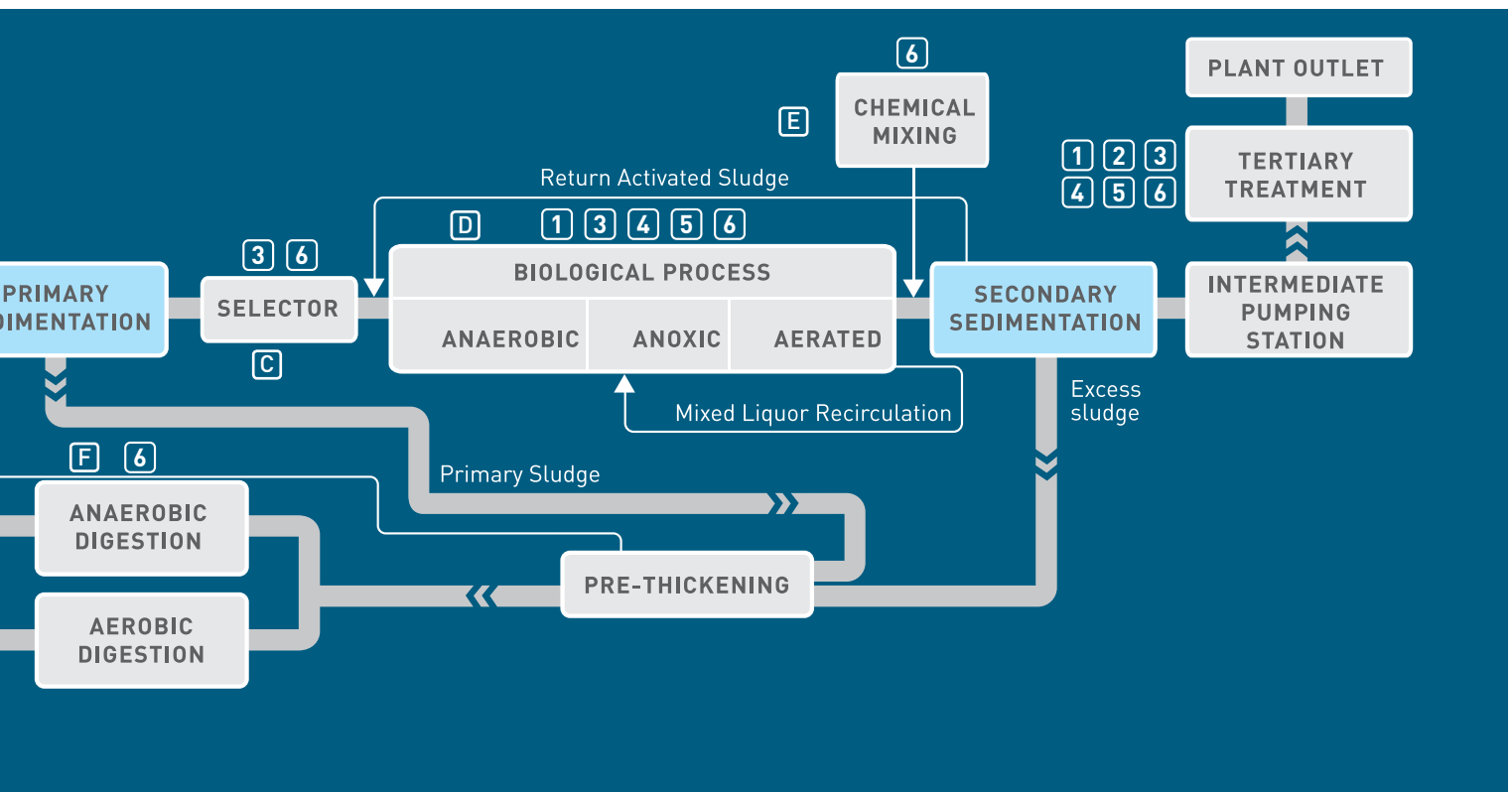

ABS SUBMERSIBLE MIXERS. FOR OPTIMIZED OPERATION.



The ABS submersible mixers are designed for economical and reliable operation and can be used in all tanks, regardless of size and shape. ABS mixer range is the result of years of experience and continuous development.

Clever propeller design

ABS propellers are specially designed to give a self-cleaning effect. The design guarantees efficient operation throughout the entire range and at all performance levels. This results in operation which is vibration-free, with steady flow operation without turbulence.

Unique coupling system

The patented ABS coupling system is a major innovation which facilitates connecting and disconnecting the submersible mixers. The mixer is lowered down on a guide rail and secured in position by a unique coupling device. Some simple grips are what is needed to disconnect and raise the mixer again, and this can be done without emptying the tank.

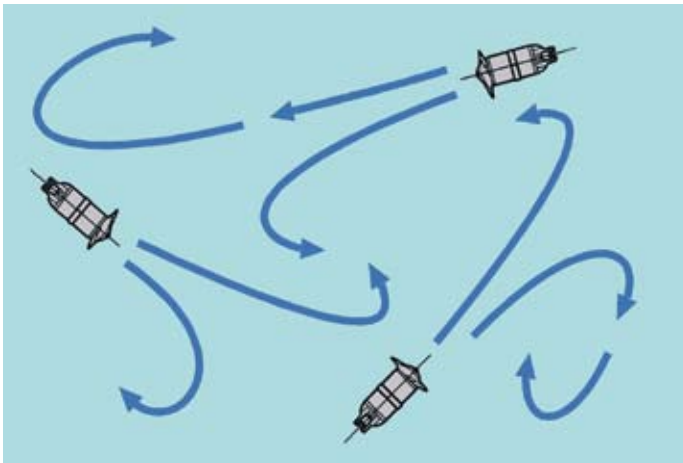

Vibrations caused by the liquid flow or by the mixing fluid itself have high impact on the propeller and must be absorbed by the coupling device. The sturdy construction of the ABS coupling system can withstand these forces without vibrating.

Flexible positioning reduces power consumption

The ABS installation system allows you to create the best conditions for high process efficiency. Using the guide rails, the mixers can be adjusted vertically to operate at the different levels and they can also be rotated to operate in different directions. ABS also offers a kit which makes it possible to angle the mixers upwards or downwards.

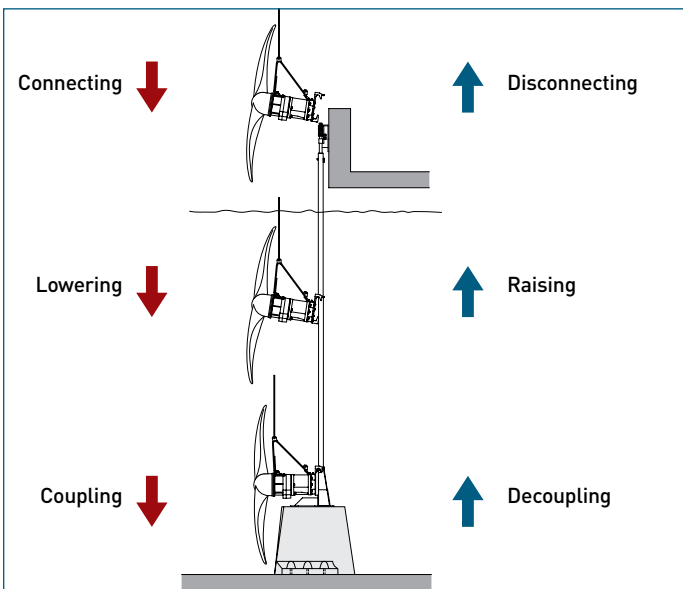

In large tanks, several mixers can be installed in different locations to achieve optimum mixing at very low power consumption. The investment costs can also be minimized as the guide rail system does not require any investments in walkways or bridges.

Top picture: ABS flow booster SB installation in an oxidation ditch.
Middle: An arrangement of mixers to ensure movement in all corners of the tank.
Bottom: ABS unique coupling system. No need to empty the tank to remove the mixer.

ABS FLOW BOOSTER SB. MAXIMUM FLOW. MINIMUM POWER CONSUMPTION.

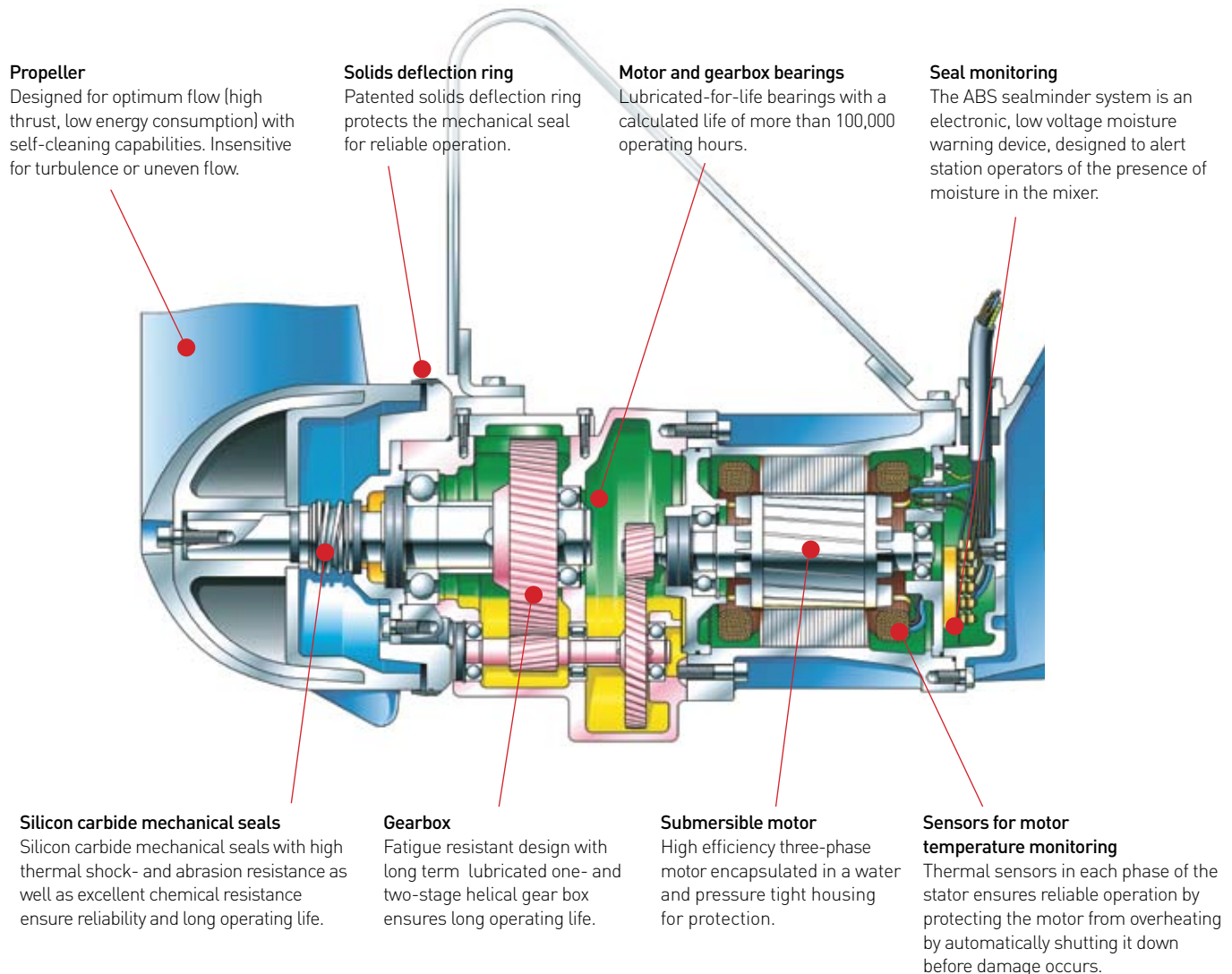

ABS flow booster SB



Slow running submersible mixer with integral motors for gentle circulation and mixing of fluids in treatment plants and industrial applications. Ideal for circulation and flow generation in the nitrification, denitrification, phosphate elimination and equalization stages. The concrete pedestal is unique for the ABS flow booster and is designed to efficiently absorb vibrations.

- The streamlined shape of the base avoids turbulence and therefore improves the efficiency of the propeller.
- The mass and material characteristics of the concrete base suppress all damaging vibrations.
- Corrosion resistance and a robust connection with the tank floor ensure the high reliability and a long operating life.

ABS SUBMERSIBLE MIXERS RW. RELIABILITY AND EFFICIENCY.

Solids deflection ring

Patented solids deflection ring protects the mechanical seal for reliable operation.

Motor and gearbox bearings

The lubricated-for-life bearings have a calculated life of more than 100,000 operating hours.

Sensors for motor temperature monitoring

Thermal sensors in each phase of the stator protect the motor from overheating, automatically shutting it down before damage can occur.

Propeller for ABS submersible mixer RW

Blades shaped for optimum flow properties make the propeller insensitive to turbulence or uneven flow. Energy-saving and self-cleaning with high thrust.

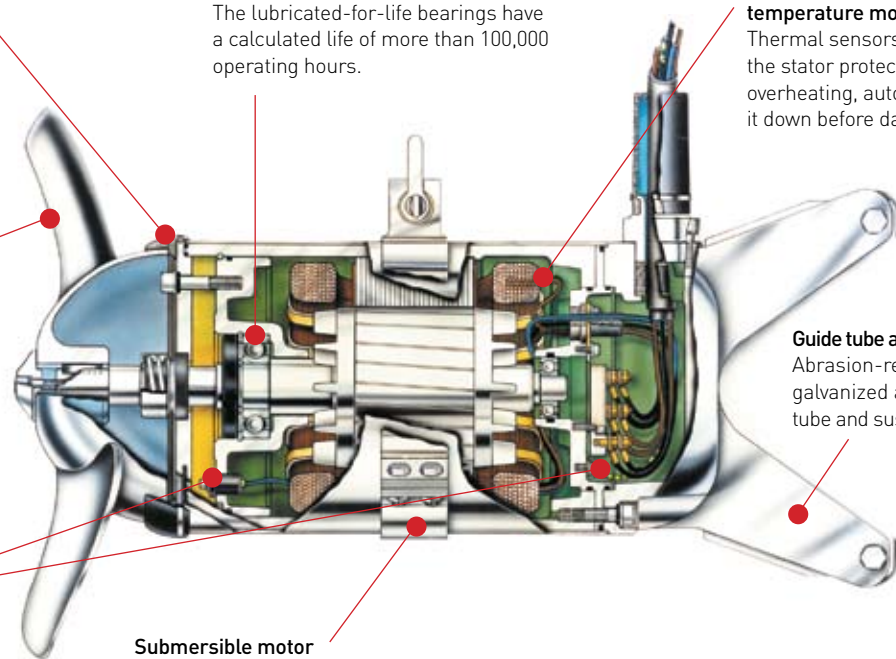

Seal monitoring

The ABS seal minder system is an electronic, low voltage moisture warning device, designed to alert station operators of the presence of moisture in the mixer.

Submersible motor

High efficiency three-phase motor, encapsulated in a water and pressure tight housing for protection.

High power reserves

High power reserves ensure continuous mixing in all situations minimizing the risk of unplanned stoppages.

Guide tube and suspension

Abrasion-resistant galvanized and insulated guide tube and suspension.

ABS submersible mixer RW 200



Compact mixer specially designed for applications within the wastewater treatment plant and for cleaning pump sumps.

- Small space requirements through compact design.
- Adjustable bracket allows direction to be altered to give greater flexibility.

ABS submersible mixer RW 300-900



Designed for a wide range of applications within the wastewater treatment plant.

- Can be used in every shape and size of tank.
- Full stainless steel versions are available.
- Hydrodynamic shape for optimum flow formation.

ABS submersible mixer RW 480



Specially designed for the major mixing functions during the homogenization of sludge and slurry.

- Self-cleaning two-blade propeller reduces Life Cycle Cost .
- Reduced energy cost due to a unique drive unit design including a highly efficient gearbox.
- Hydrodynamic shape for optimum flow formation.

ABS FLOW BOOSTER SB 1200 KA. FOR APPLICATIONS WITH PLASTIC CARRIERS.

ABS flow booster SB 1200 KA



The ABS flow booster SB 1200 KA has been developed specifically as a result of our experience working with treatment plants using moving bed biofilm reactor (MBBR) in the biological process.

The biofilm plastic carriers used in the MBBR process have a lower density than water and float towards the surface of the wastewater. ABS has developed a special mixer, ABS flow booster SB 1200 KA, for the MBBR applications. The mixer is designed to keep these carriers in circulation in the tank. The low tip speed and a rounded propeller front edge of the SB 1200 KA avoid disruption of the biofilm carriers which is a typical concern in the MBBR process.

The ABS flow booster SB 1200 KA offers the following advantages for this application:

- Uniquely designed for the mixing of plastic carriers.
- Low tip speed to avoid the disruption of biofilm plastic carriers.
- Smooth rounded propeller front edge avoid disruption of the biofilm carriers.
- Solid deflection ring for avoiding penetration of plastic carriers into the hub.
- The SB 1200 KA use the same modular components as the submersible mixer RW and has thereby the same key advantages of the reliable and robust motor design.



Top picture: The uniquely designed ABS flow booster SB 1200 KA for the mixing of plastic carriers.
Two middle pictures: Close-ups of plastic carriers covered with microorganism.
Bottom picture: Biofilm carriers mixed in the reactor.

ABS SCABA AGITATORS. TAILOR-MADE SOLUTIONS.

The dry-installed agitators from ABS can successfully be applied in many stages of the wastewater treatment process for example in the neutralization and flocculation processes, the selector tank, the biological process, the anaerobic digestion and in the sludge buffer tank.

Customized agitators for reduced energy consumption

The agitators are of robust modular design and can be combined with various types of drive units, seals and propellers. The major benefit of the ABS Scaba range is the possibility to customize to achieve optimum efficiency and reliability. The modular ABS Scaba range enables high level of customization using standard components.

The driving force for the customization is to strive for maximum agitation with minimal use of power.

Computer-aided design program

Many factors effect the process and mechanical aspects of the design procedure. Important considerations are type of process, type of liquid, volume, the shape of the tank etc. In some applications the density, viscosity and solid content are the dominant factors. The ABS Scaba agitator is individually tailored for different types of liquids. The side entry agitator is suitable for liquids with viscosities up to 1,000 mPa and the top entry agitator for liquids, liquid-solids and liquid-gas, up to 100,000 mPa.

In order to establish the correct dimension of the agitator for a specific tank ABS use a design model taking the velocity at the liquid surface into consideration when calculating the agitation in a tank. The speed at the bottom of the tank is always higher than at the surface, therefore it is more reliable to measure the surface speed when designing the agitator. All calculations are done with a computerized program which is also used to configure the optimal ABS Scaba agitator – tailor made for the process conditions.



Pedestal module options

The pedestal module is equipped with sleeve and flange couplings as standard, but the optional choice is a double spherical roller bearing with adapter sleeve. No bottom bearing minimizes maintenance.

- Flange or sleeve coupling
- Radially split coupling
- Double spherical roller bearings
- Stuffing box
- Single or double mechanical seal
- Labyrinth, TH and TS seals
- Shaft length up to 30 m

Drive unit options

The drive unit is selected based on unique process requirements and can be equipped with gears, parallel shaft gears, bevel gears or V-belt drives.

- Power rating 0.15 - 67 hp
- Electric, hydraulic or pneumatic

Propeller options

The patented Scaba propeller gives the required process result at the lowest possible power input and is available with many types of seal and material options. The blade shape of the high flow propeller gives an efficient and even mixing with less vibration.

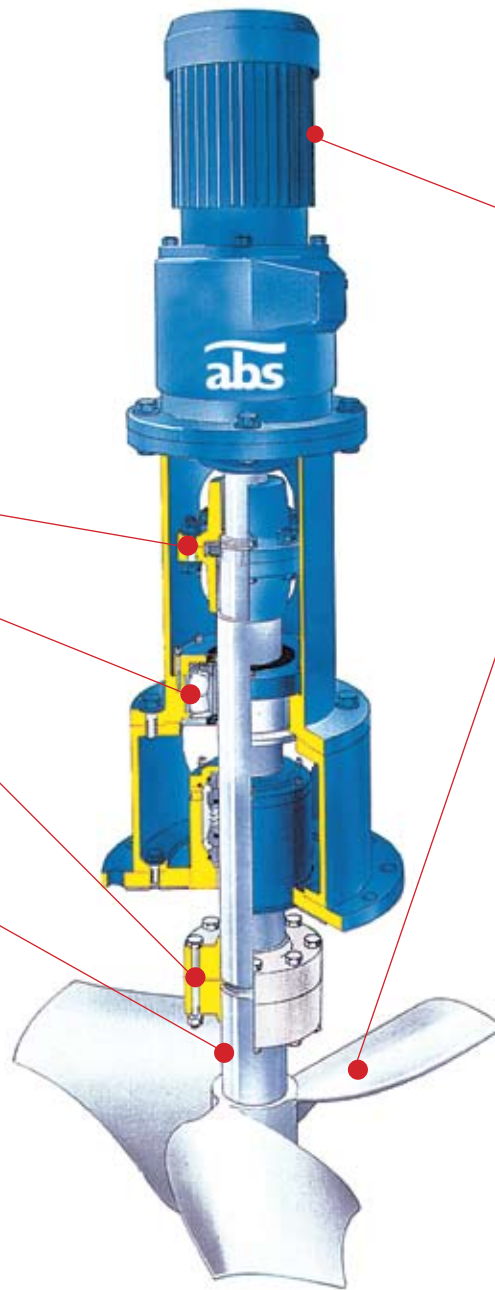

ABS Scaba agitator



The ABS Scaba agitator is all about customization. Shaft lengths, propeller sizes, type of motor, top or side entry installation are only the basics - every agitator that leaves the ABS manufacturing is specifically configured to match its designated process in the wastewater treatment plant.

- Process guarantee for all applications.
- High-efficiency propeller.
- No risk of sedimentation.
- Good axial flow.
- Few spare parts enable quick and easy maintenance.
- Same modular system for all agitators increases flexibility.